



SE-2054-2

REF SE20542NR29

Key Features

- Tested & certified to redundant safety standards.
- Ready to fit in. No extra development cost.
- Smart battery system compliant to SBS v1.1
- SMBus v1.1 communication support.
- 5-Segment LED State of Charge (SoC) indicator.
- UL-94 V-0 rated ABS enclosure.
- Industry standard 5 pin connector.
- JEITA charging profile optimization.
- ESD protection up to 8kV
- SHA-1 cryptosystem to prevent plagiarism
- UL certified INR-18650 2.85Ah Lithium-Ion cells

Description:

The SE20542NR29 is a 14.4V 5.7Ah (82.08Wh) Lithium ion smart battery which can be used in a numerous portable equipments. The battery comprises eight 3.6V 2.85Ah INR-18650 cells in a 4-series, 2-parallel array and can deliver up to 6A of discharge current. The internal battery management system (BMS) is System Management Bus (SMBus) and Smart Battery System (SBS) compliant and can operate as part of a smart battery system along with a compatible smart charger and host device.

Applications

- Medical
- Solar
- Wind
- Mobility
- Data Center
- Transport
- Sports
- Recreation
- Utility



Self Declaration:
Conforming to
IS16046: 2018
R-91005673

Rechargeable Li-ion Battery 14.4V 5.7Ah 82.08Wh

Protection

- Over charge
- Over discharge
- Over current
- Over temperature
- Short-circuit
- Reverse polarity

Approvals

- ISO 9001:2015
- IEC 62133 : 2017
- ISO 13485:2016
- CE
- UN 38.3
- BIS 16046:2018

Technical Specification:-

Part number	SE20542NR29
Pack designation	41NR19/65-2
Brand	SES
Chemistry	Lithium Ion
Nominal Voltage	14.4 V
Nominal Capacity	5700 mAh
Nominal Energy	82.08 Wh
Discharge current Max.	6.0 A
Discharge power Max.	86.4 W
Charging Voltage Max.	16.8 V
Charging Current Max.	2.9 A
Charge indicator	5 Segment, LED
Communication	SMBus v1.1
Data System	SBS v1.1
Charge	-20°C to +55°C
Discharge	-20°C to +55°C
Storage	-20°C to +55°C
Storage Temperature	+20°C to +70°C
Other	
Dimension (L x W x H)	151.0 x 77.4 x 22.5 mm ± 0.5mm
Weight (typical)	500 gm ± 20gm

Manufactured by : **SEALED ENERGY SYSTEMS**



Plot No. 72, HSIIDC Industrial Estate,
Ambala Cantt -133006, Haryana, India



+91 171 2699 054
+91 171 2698 389



+91 171 2698 054
+91 171 2699 221



Rechargeable Li-ion Battery 14.4V 5.7Ah 82.08Wh

Rate discharge curve@ 25°C

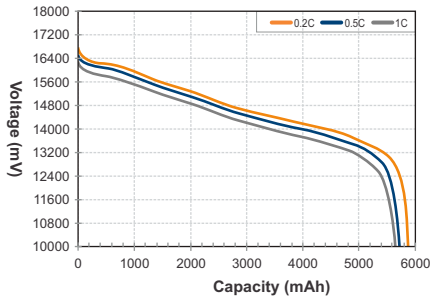

Discharge curve at different temperatures

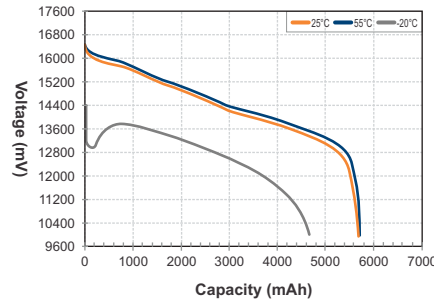

Rate charge curve@ 25°C

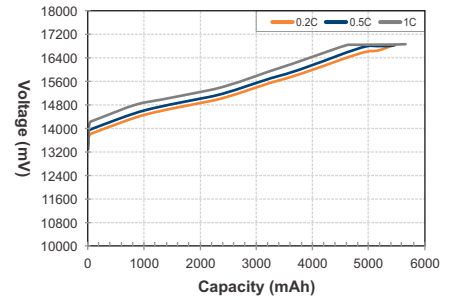

Cycle life curve@ 25°C

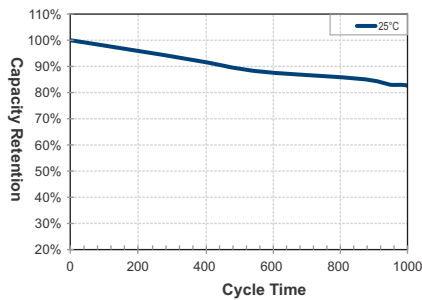

High temperature cycle life curves

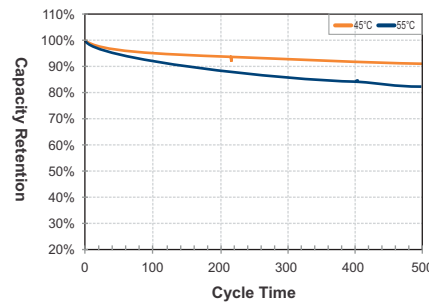

Chargers

SES® offers suitable chargers for batteries with a variety of capacities.

Refer to our website for more information on our switch mode type chargers.

Please contact our technical department for advice if you have difficulty in locating a suitable charger.

Further Information

Please refer to our website www.sesbatteries.co for a complete range of useful downloads, such as product catalogs, material safety data sheets (MSDS), ISO certification, etc.

Product Dimension

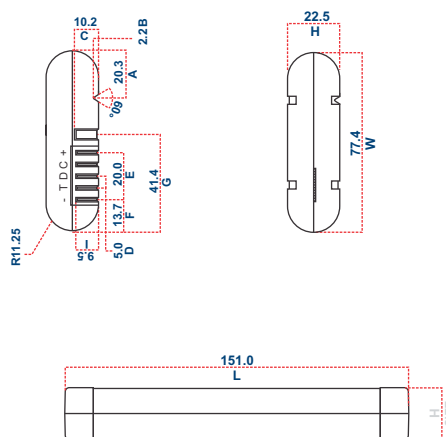
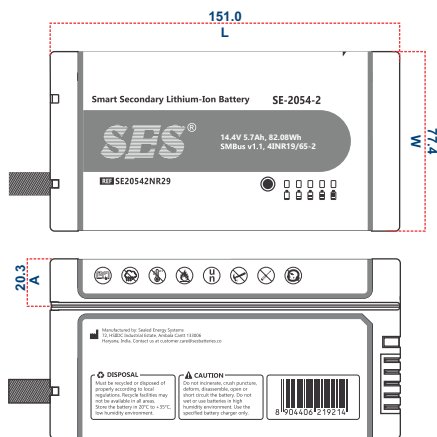

Dimensions are in Millimeters	
Tolerances: ±0.5mm	
L : 151.0	W : 77.4
H : 22.5	A : 20.3
D : 5.0	C : 10.2
F : 13.7	E : 20.0
I : 9.5	G : 41.4



Self Declaration:
Conforming to
IS16046: 2018
R-91005673

Manufactured by : **SEALED ENERGY SYSTEMS**

Plot No. 72, HSIIDC Industrial Estate,
Ambala Cantt -133006, Haryana, India

+91 171 2699 054 +91 171 2698 054
+91 171 2698 389 +91 171 2699 221