



ST-25100L

REF ST25100LNR29

This ST-25100L battery is rechargeable lithium-ion, engineered and designed for use in a world wide tactical environment, and is manufactured to meet and exceed Indian military standard JSS-55555 and ISO-9000 methods and procedures. This battery meets the requirements of JSS 6140-03 : 2013 and MIL-PRF-32052 with reference to MIL-STD-810E and MIL-STD-461.

Key Features

- Standard power battery, 287Wh
- Wide operating temperature range
- Durable high impact Aluminum case
- High energy density cells
- Indigenous connector construction

Typical Applications

- STAR V, 25W MK-II, RADIO SET
- Surveillance equipment
- Remote control electronics
- Portable Manpack Power bank
- Rugged portable electronics

Rechargeable Li-ion Battery
25.2V 11.4Ah, 287.28Wh

Compliance

- JSS-55555
- JSS-6140-03 : 2013
- MIL-STD-810E
- MIL-STD-32052

Approvals

- ISO 9001:2015
- ISO 13485:2016
- Safety Datasheet
- UL-1642 (cells)

Technical Specification:-

Part Number	ST-25100L
Pack Designation	71NR19/65-4
Capacity (typ.)	11.4 AH
Nom. Voltage	25.2 Volt
Max. Voltage	29.4 Volt
Max. Discharge Current (cont.)	10.0 A
Max. Discharge Current (pulse)	15.0 A for 10 Sec.
Cat P/No.	Z9/6140-005208
Life Cycle	1000 cycles at 25°C
Communication	None
Recommended charge	Constant current at C/4 , 2.85A with 16.8V limit, End with timer or when current drops below 0.1A
Physical Characteristics	
Dimensions (L x W x H)	261 x 89 x 110 mm
Weight	2.3 Kg ± 0.10 Kg.
Weight energy density	112 Wh/Kg
Connector	2-Way Female Floating Socket
Battery Housing	High impact Aluminum casing
Color	Olive drab / Black



Li-ion





Rechargeable Li-ion Battery 25.2V 11.4Ah, 287.28Wh

Rate discharge curve@ 25°C

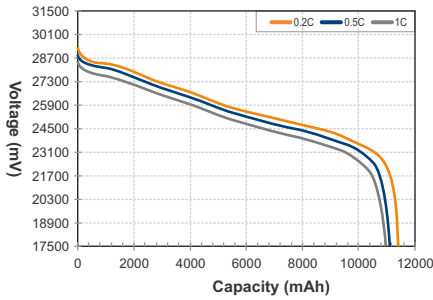

Discharge curve at different temperatures

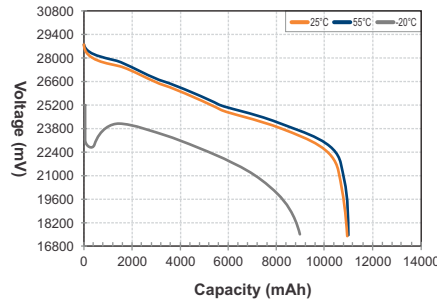

Rate charge curve@ 25°C

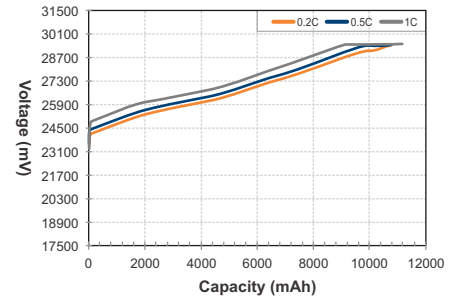

Protection

- Over current / short circuit
- Over charge / over discharge
- Over heating
- Charging at over temperature range
- Reverse polarity

Smart Functions

- Cell balancing

Operating Temperature

- Charge -20°C to +55°C
- Discharge -20°C to +55°C
- Storage -20°C to +55°C
- Humidity at 0 to 95%

Storage

- Allowable: -20 to +55°C
- Recommended: +20 to +40°C
- Humidity at 0 to 95%

Transportation

- UN 38.3 Miscellaneous Class 9

Further Information

Please refer to our website www.sesbatteries.co for a complete range of useful downloads, such as product catalogs, material safety data sheets (MSDS), ISO certification, etc.

Cycle life curve@ 25°C

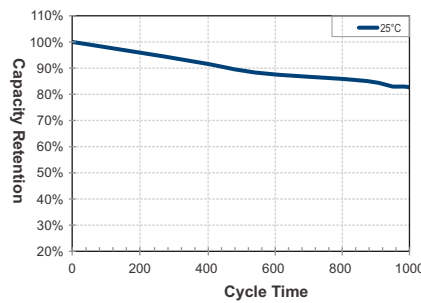

High temperature cycle life curves

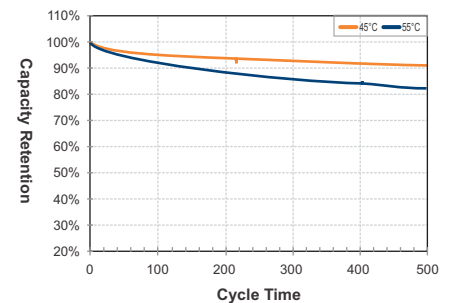

Product Dimension

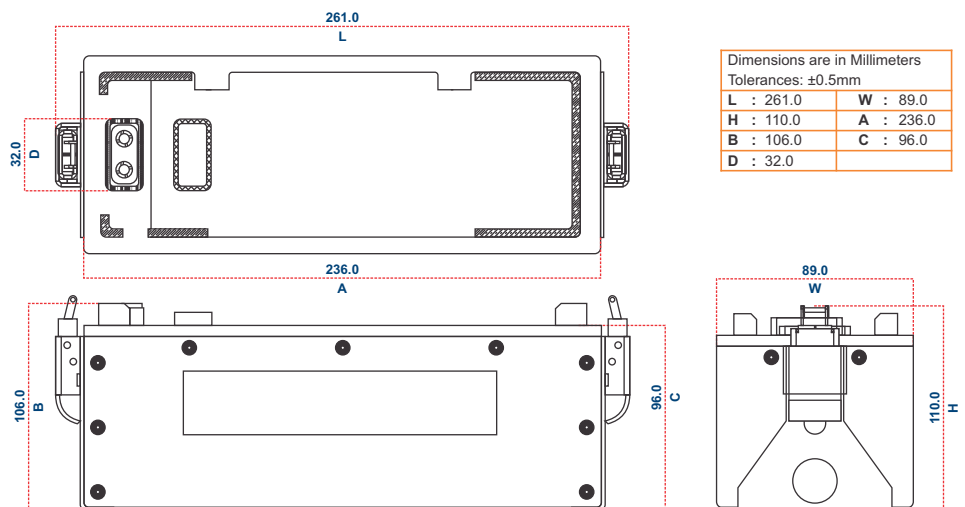

Manufactured by: **SEALED ENERGY SYSTEMS**

Plot No. 72, HSIIDC Industrial Estate, Ambala Cantt -133006, Haryana, India

+91 171 2699 054 +91 171 2698 054
+91 171 2698 389 +91 171 2699 221