



Image only for reference

# SE-2020

## Rechargeable Li-ion Battery

REF SE20200NR22

REF SE20200NR26

REF SE20200NR29

REF SE20200NR32

REF SE20200NR35

### Key Features

- Tested & certified to redundant safety standards.
- Smart battery system compliant to SBS v1.1
- 5-Segment LED State of Charge (SoC) indicator.
- Industry standard 5 pin connector.
- ESD protection up to 8kV
- Ready to fit in. No extra development cost.
- SMBus v1.1 communication support.
- UL-94 V-0 rated ABS enclosure.
- JEITA charging profile optimization.
- SHA-1 cryptosystem to prevent plagiarism

### Protection

- Over charge
- Over discharge
- Over current
- Over temperature
- Short-circuit
- Reverse polarity

### Technical Specification:-

Part number	SE20200NR22	SE20200NR26	SE20200NR29	SE20200NR32	SE20200NR35
Pack designation	3INR19/65-3	3INR19/65-3	3INR19/65-3	3INR19/65-3	3INR19/65-3
Brand	SES	SES	SES	SES	SES
Chemistry	Lithium Ion	Lithium Ion	Lithium Ion	Lithium Ion	Lithium Ion
Nominal Voltage	10.8 V	10.8 V	10.8 V	10.8 V	10.8 V
Nominal Capacity	6600 mAh	7650 mAh	8550 mAh	9600 mAh	10200 mAh
Nominal Energy	71.28 Wh	82.62 Wh	92.34 Wh	103.68 Wh	110.16 Wh
Discharge current Max.	6.0 A	6.0 A	6.0 A	6.0 A	6.0 A
Discharge power Max.	64.8 W	64.8 W	64.8 W	64.8 W	64.8 W
Charging Voltage Max.	12.6 V	12.6 V	12.6 V	12.6 V	12.6 V
Charging Current Max.	4.35 A	4.35 A	4.35 A	4.35 A	4.35 A
Charge indicator	5 Segment, LED	5 Segment, LED	5 Segment, LED	5 Segment, LED	5 Segment, LED
Communication	SMBus v1.1	SMBus v1.1	SMBus v1.1	SMBus v1.1	SMBus v1.1
Data System	SBS v1.1	SBS v1.1	SBS v1.1	SBS v1.1	SBS v1.1
Charge	-20°C to +45°C	-20°C to +45°C	-20°C to +45°C	-20°C to +45°C	-20°C to +45°C
Discharge	-20°C to +45°C	-20°C to +45°C	-20°C to +45°C	-20°C to +45°C	-20°C to +45°C
Storage	-20°C to +45°C	-20°C to +45°C	-20°C to +45°C	-20°C to +45°C	-20°C to +45°C
Storage Temperature	+20°C to +35°C	+20°C to +35°C	+20°C to +35°C	+20°C to +35°C	+20°C to +35°C

### Other

Dimension (L x W x H) 148.8 x 89.0 x 20.2mm ± 0.5 gm

Weight (typical) 460 gm ± 20 gm

Manufactured by: **SEALED ENERGY SYSTEMS**

 Plot No. 72, HSIIDC Industrial Estate, Ambala Cantt -133006, Haryana, India

 +91 171 2699 054  +91 171 2698 054  
 +91 171 2698 389  +91 171 2699 221

# Rechargeable Li-ion Battery



Image only for reference

## Product Dimension

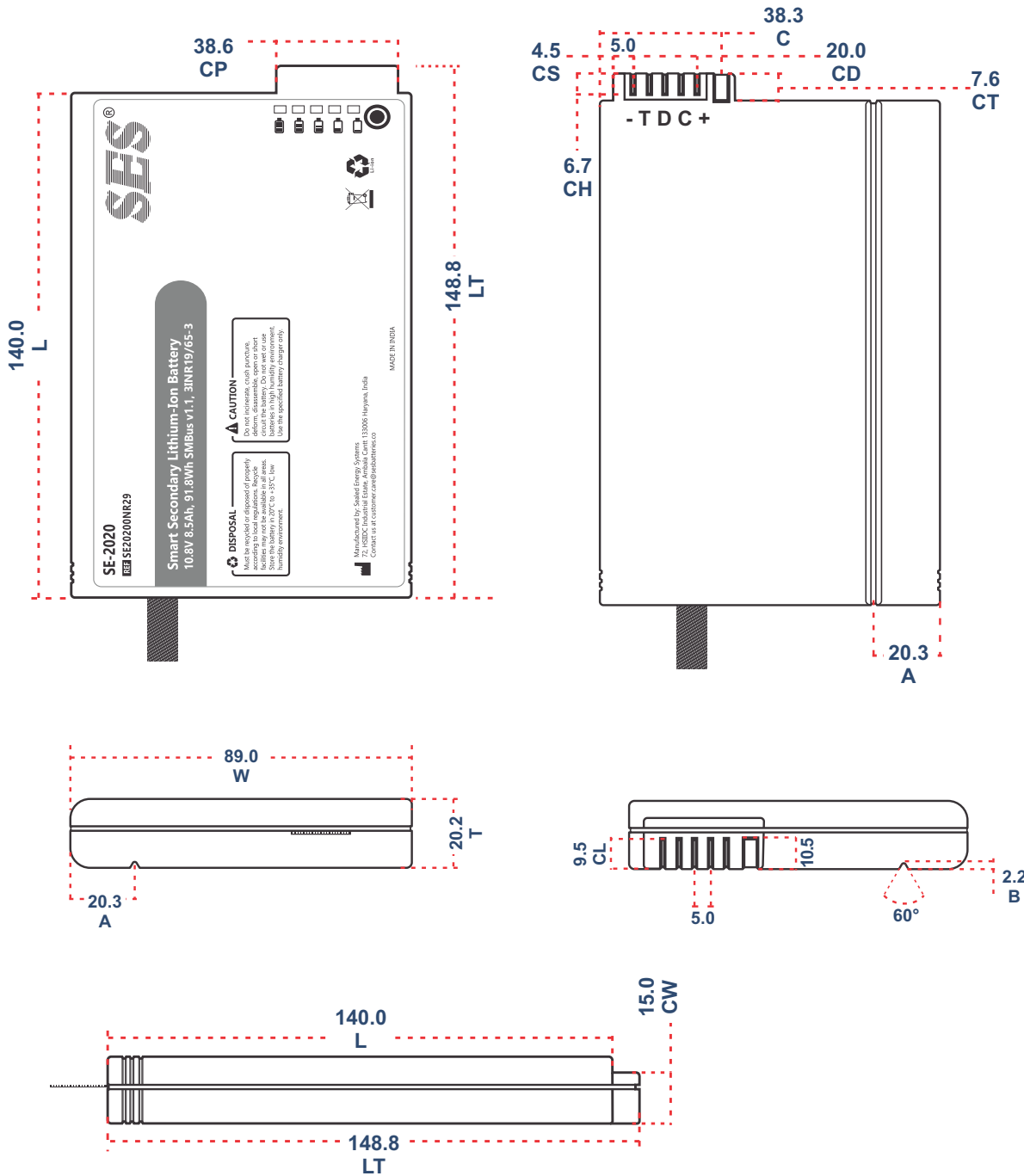

Dimensions are in Millimeters	
Tolerances: ±0.5mm	
LT : 148.8	L : 140.0
W : 89.0	T : 20.2
CP : 38.6	C : 38.3
CS : 4.5	CH : 6.7
CT : 7.6	CL : 9.5
A : 20.3	B : 2.2